

# **RCBS**<sup>®</sup>

---

## **MINI GRAND**

**SINGLE STAGE SHOTSHELL RELOADING PRESS**

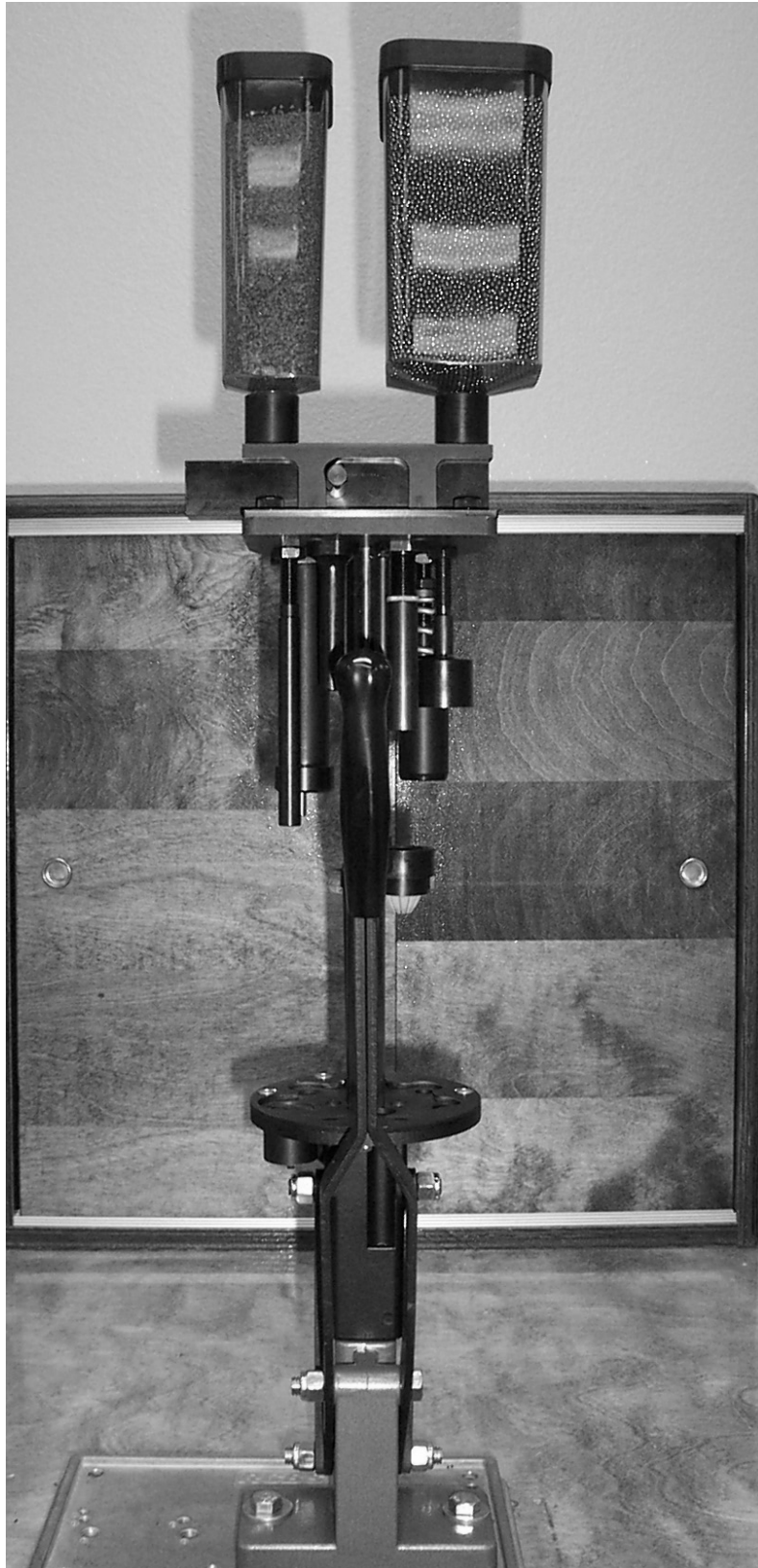

## **PRODUCT INSTRUCTIONS**

## **IMPORTANT**

Before using the RCBS Mini-Grand Shot Shell Press, read these instructions carefully to fully learn how to safely operate the related reloading equipment. Failure to properly operate certain reloading equipment can result in severe personal injury and/or equipment damage.

**If you have any questions while assembling or operating this tool,  
call us at 1-800-533-5000 or 1-530-533-5191**

**Monday – Thursday 6:30 a.m. to 3:00 p.m. Pacific Time**

*The instruction manual contains specific safety and operating information. It should be considered a permanent part of your reloading equipment and remain with the equipment at all times for easy reference.*

## **SAFETY**

Reloading is an enjoyable and rewarding hobby that can be conducted safely. But, as with any hobby, carelessness or negligence can make reloading hazardous. This product has been designed from the beginning with the user's safety in mind. When reloading, safety rules must be followed. By observing these rules, the chance of a hazardous occurrence causing personal injury or property damage is minimized.

## **GENERAL**

- Use all equipment as the manufacturer recommends. Study the instructions carefully and become thoroughly familiar with the operation of the product. If you do not have written instructions, request a copy from the equipment manufacturer.
- Don't take short cuts. Attempting to bypass established procedure is an invitation to an accident.
- Observe "good housekeeping" in the reloading area. Keep tools and components neat, clean and orderly. Promptly and completely clean up primer and powder spills.
- Reload only when you can give your undivided attention. Do not reload when fatigued or ill, or under the influence of medications or alcohol.
- Develop a reloading routine to avoid mistakes which may prove hazardous. Don't rush - load at a leisurely pace.
- Always wear adequate eye protection to protect your eyes from flying particles. You assume unnecessary risk when reloading without wearing safety glasses.

## **LOADING DATA**

- Use only laboratory tested reloading data. There are many lab tested shotshell manuals available. Always follow the load data exactly as it is published in any shotshell reloading manual.
- Never substitute components
- **OBSERVE ALL WARNINGS ABOUT THE USE OF MAXIMUM LISTED LOADS**

## **PRIMERS AND POWDER**

- Store primers and powder beyond the reach of children and away from heat, dampness, open flames and electrical equipment. Avoid areas where static electricity is evident.
- Do not use primers of unknown identity.
- Dispose of unknown primers in accordance with applicable regulations.
- Keep primers in the original factory container until ready to use. Return unused primers to the same factory packaging for safety and to preserve their identity. Primer packaging is designed to provide safe storage.
- **DO NOT** store primers in bulk. The blast of just a few hundred primers is sufficient to cause serious injury to anyone nearby.
- **DO NOT** force primers. Use care in handling primers.
- **DO NOT** have more than one can of powder on the bench at one time. Powder cans should be stored away from the bench to avoid picking up the wrong one.
- **DO NOT** use any powder unless its identity is positively known. The only positive identification is the manufacturer's label on the original canister. Discard all mixed powder and those of uncertain identity.
- Always replace the lids on both the powder hopper and shot hoppers after they have been filled.
- When you finish a reloading session, pour any remaining powder back into its original factory container. This will preserve the identity and shelf life of the powder.
- **DO NOT** smoke while reloading.

## **RECORD KEEPING**

- Keep complete records of reloads. Apply a descriptive label to each box showing the date produced, and the primer, powder, wad and shot used.
- Never attempt to guess at the identity of your ammunition.

*Because RCBS has no control over the choice of components, the manner in which they are assembled, the use of this product, or the firearms in which the resulting ammunition may be used, we assume no responsibility, expressed or implied, for the use of ammunition reloaded with this product.*

## PRESS MOUNTING

**Step 1** Mount your press to a solid bench. Presses mounted to a weak or flexible bench are a safety hazard and will not produce a consistent round. Select an area of your bench with approximately one foot clearance on either side of the Mini Grand.



**Step 2** Install Hopper/Charge Bar assembly onto press frame. Place assembly onto top of press frame and attached with Thumbscrews provided.

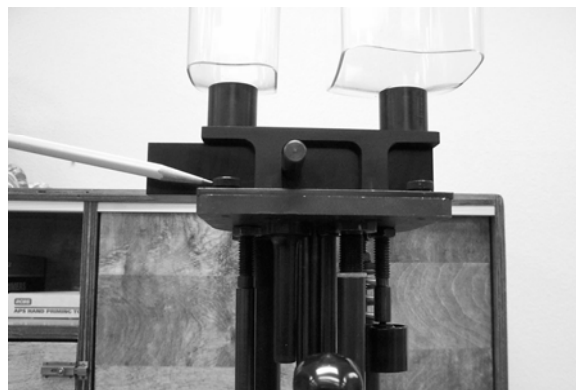

**Step 3** Install Spent Primer Catcher

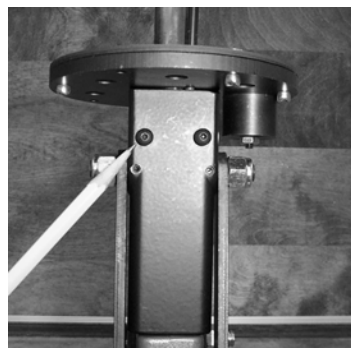
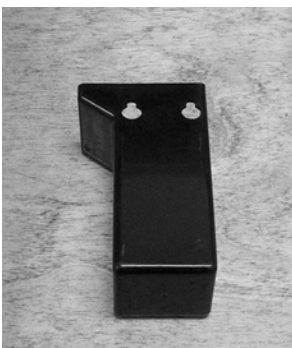

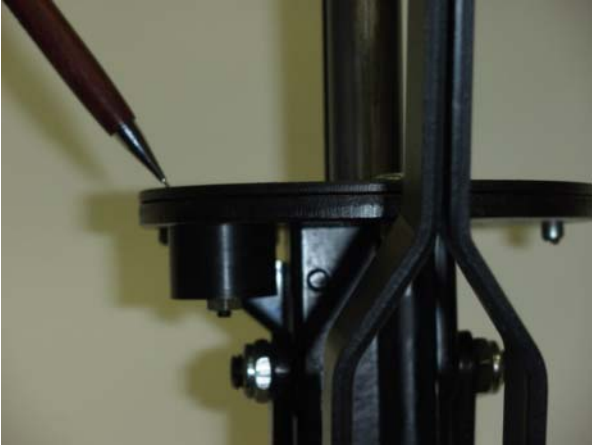

- Insert the Primer Cup Assembly into Station 2

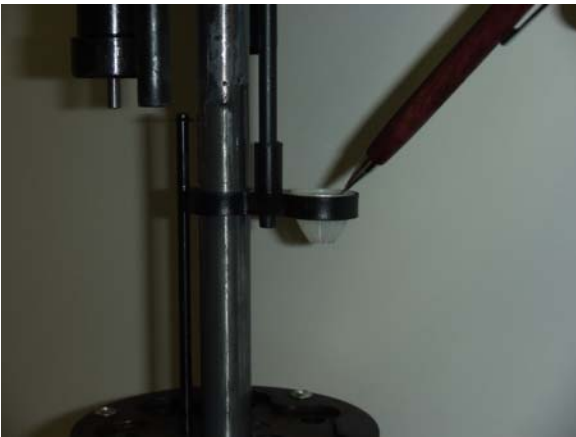

- Insert Wad Guide at Station 4

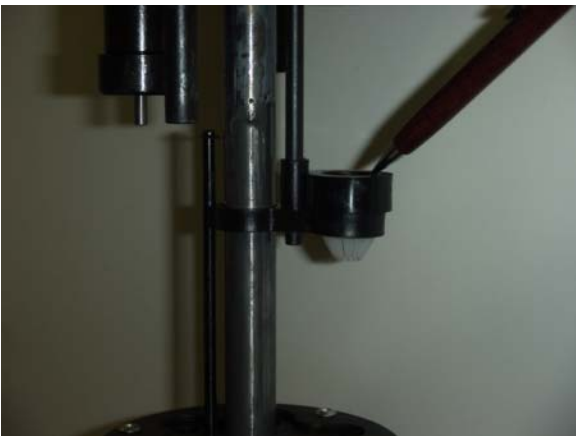

- Install Wad Holder Cap. Place cap on the Wad Holder and turn counter clockwise to lock in place.

## PRESS FUNCTION BY STATION

The Mini Grand is a single stage shotshell reloader. Hulls must be moved from station to station manually.

### Station 1

Sizing and removal of spent primer.

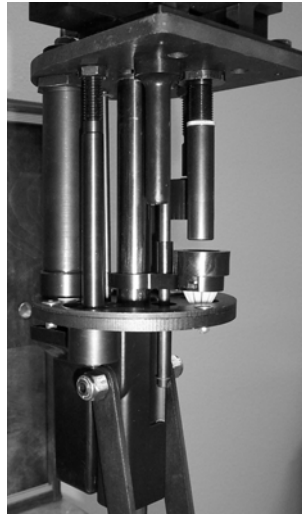

### Station 2

Priming: Primers are inserted manually, the hull is placed in the station and primers are seated by “feel”. Full cycling of the handle is not achieved at this station.

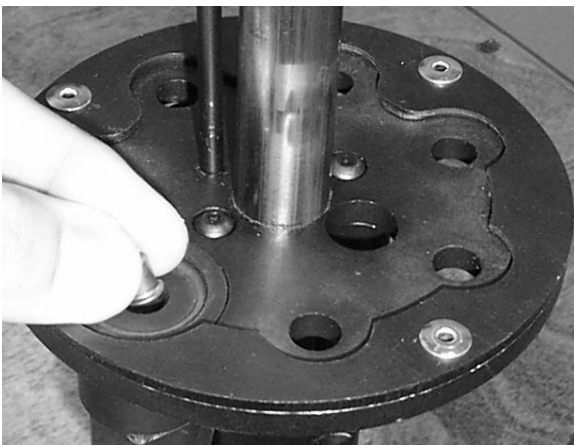

### Station 3

Powder Charge: Powder is dispensed into the hull by sliding the Charge Bar Handle to the right.

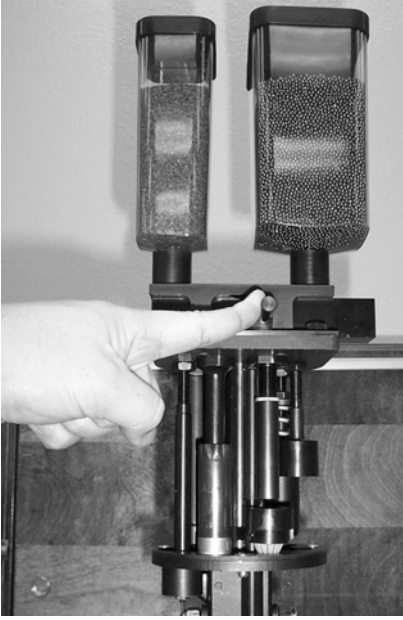

### Station 4

Wad Seating and Shot Charge: Insert wad into Wad Guide and cycle handle to the down position. The wad is seated into the hull. Slide the Charge Bar Handle to the left to dispense the shot charge.

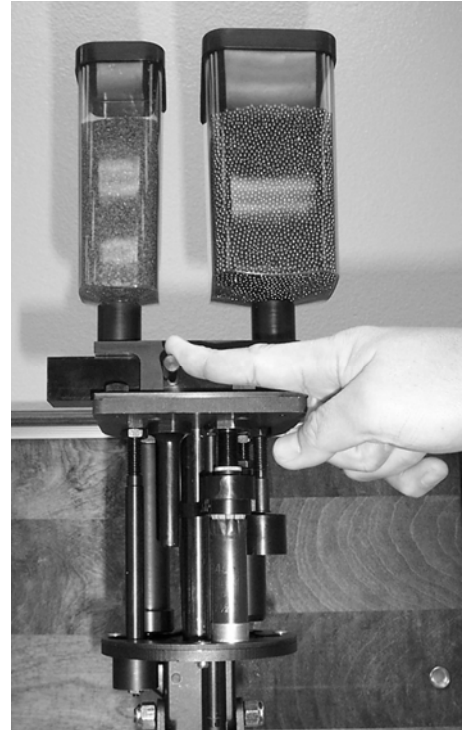



### Station 5

Start Crimp: An 8 point crimp starter is installed from the factory. A 6 point crimp starter is included in the accessory bag.



### Station 6

Crimp



### Station 7

Empty, allows for the installation of an optional Taper Crimp die assembly.

## **FILL POWDER AND SHOT HOPPERS**

Remove the Powder Hopper Cap and fill with desired powder, replace Cap. Capacity is approximately ½ pound of smokeless powder.

Remove the Shot Hopper Cap and fill with desired shot, replace Cap. Capacity is 12 ½ pounds of shot.

## **PRESS OPERATION**

### **STEP ONE (Resize and Deprime)**

Insert a hull into Station 1. Be sure that the shell plate holder captures the rim of the hull. Completely cycle the Handle. The hull has been sized and deprimed.

### **STEP TWO (Priming)**

Insert a primer into the Primer Cavity in the Shell Plate assembly at station 2. Move the hull to Station 2 and depress the Handle. Full travel of the Handle will not be realized at this station. Check that the primer is seated flush with the base of the hull.

### **STEP THREE (Powder Charge)**

Move the hull to station 3. Depress the handle to the bottom and then slide the Charge Bar to the right. Powder is dispensed into the hull. Raise the handle.

### **STEP FOUR (Wad Seating and Shot Charge)**

Move the hull to station 4. Insert a wad into the Wad Guide. Wads can be inserted at any point in the loading process, as they will not be seated unless a hull is present at station 4. Depress the handle to the bottom and then slide the Charge Bar to the left. Return the handle to the up position. The wad is seated and the shot charge is dispensed.

### **STEP FIVE (Start Crimp)**

Move the hull to station 5 and depress the handle to the bottom of the stroke. Cycling the handle will complete the crimp start.

### **STEP SIX (Finish Crimp)**

Move the hull to station 6 and depress the handle to the bottom of the stroke. Cycling the handle will complete the finish crimp and produce a loaded round.

If you are shooting a pump action or semi-automatic shotgun, the optional Taper Crimp die assembly (not included) may be necessary for proper functioning in your firearm.

## **COMPONENT ADJUSTMENT**

**Sizing:** The Mini Grand sizes the brass head of the hull. No adjustments are necessary at this operation.

**Priming:** As priming is accomplished by “feel”, no adjustments are necessary.

**Powder and Shot Bushing changes:** refer to Powder and Shot Bushing change instructions **on pages 8 & 9.**

**Wad Seating:** Adjusting the Lower Shot Drop Tube up or down will control the wad seating depth. Loosen brass lock ring and adjust the Lower Shot Drop Tube up or down and retighten the brass lock ring. When seating the wads, it is critical that the top of the shot column falls below the crimp area of the hull. If not, buckling of the hulls will occur. The installed shot drop tube will accommodate up to #5 size lead shot. The use of larger size shot requires the installation of the optional Steel Shot Conversion. The Steel Shot conversion does not allow for a mechanical adjustment for wad seating depth. An adjustable “witness” mark allows you to visually seat the wads to the same depth by referencing off the hull mouth.



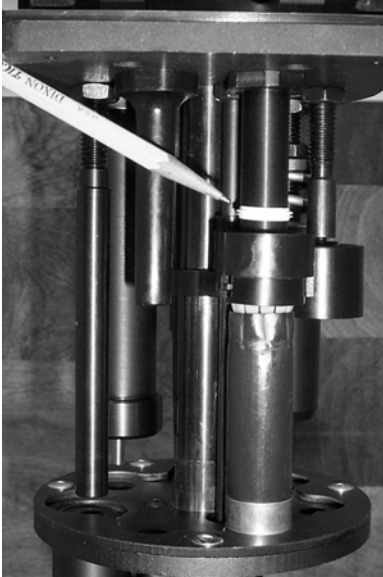

**Crimp Start adjustment:** This is an up or down adjustment. Adjusting the amount of crimp start will control the “hole” in the center of the loaded round. Too little crimp start will leave a hole that shot may spill out of. Too much crimp start can cause a “swirl” in the center of the crimp or cause a “buckle” near the top of the loaded round.

**Crimp:** This is an up or down adjustment. Adjust to your desired finished crimp depth. Adding spring pressure will flatten out a concave crimp. Reducing spring pressure will flatten out a peaked crimp.

#### **DRAIN POWDER AND SHOT HOPPERS**

Remove the two thumbscrews that attach the Hopper/Charge Bar assembly to the top of the press. Carefully remove the assembly from the press. Remove the cap from one Hopper and secure the cap on the other Hopper as you drain. Repeat for the other Hopper. It is recommended to drain the Shot Hopper before the Powder Hopper



#### **POWDER AND SHOT BUSHING CHANGE**

Drain Powder and Shot Hoppers as described above. Unscrew Charge Bar Handle from center of Charge Bar. Slide Charge Bar out of assembly. Replace Bushing(s). When reinstalling the Charge Bar, be sure that the smaller diameter Powder Bushing is to the left and the larger diameter Shot Bushing is to the right. Reinstall the Charge Bar Handle.

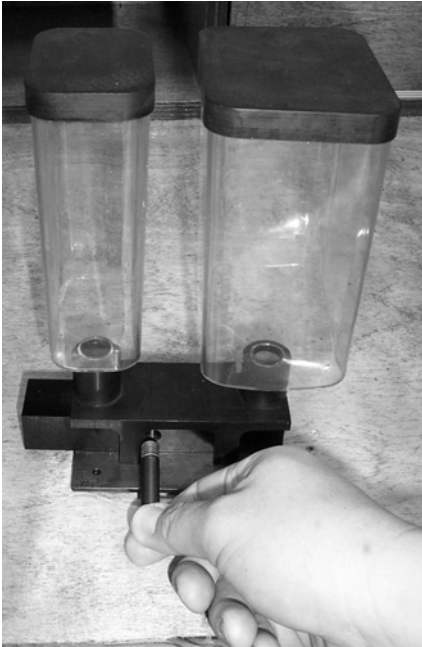

### **SPENT PRIMER CATCHER**

To empty, simply raise up and off of the mounting screws. Empty into appropriate waste receptacle and replace.

### **TROUBLESHOOTING**

It is normal for certain types of hulls to stick to the Priming Support Rod during the priming operation, simply press down on the hull mouth and the hull will drop free. This is due to the various inner base wad configurations between manufacturers.

Bad Crimps are almost always due to using the wrong crimp starter or not having the correct wad. This is frequently due to incorrect or outdated information found in reloading handbooks or literature supplied by component manufacturers. If you do not get a good crimp, check your component combination and bushings to insure that they are correct. Crimp is also selective to the individual user, what looks good or bad to you may be opposite for someone else. Set crimp depth to your personal preference.

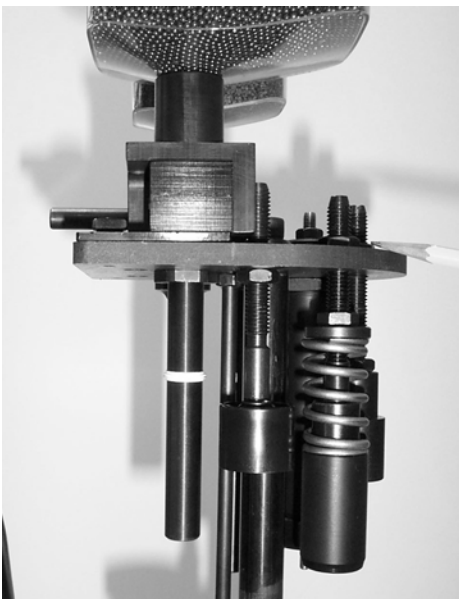

Hole in the middle of the crimp – not enough crimp start. Adjust Crimp Start die down in ¼ turn increments until desired crimp is achieved.

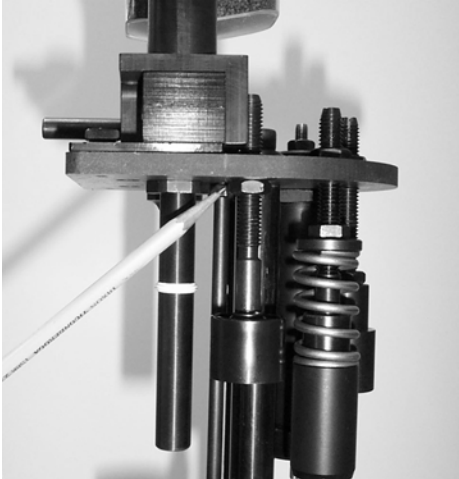

Concave crimp – not enough spring pressure. Adjust nut above the spring to increase spring pressure at station 6.  
Peaked crimp – wad not seated deeply enough or too much spring pressure at station 6.

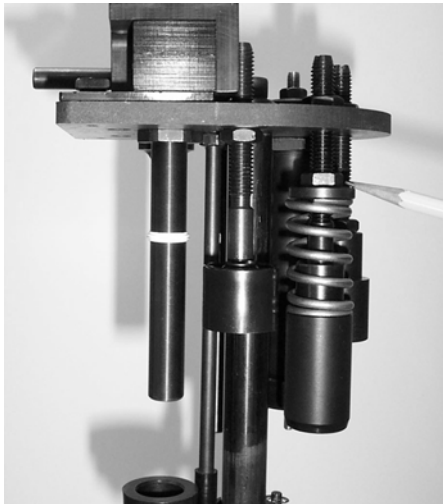

Inconsistent shot charges or shot dispenses when the Charge Bar Handle is cycled to the left. This is a bridging issue. Typically too large a size shot is being used. Shot larger than #5 requires the Steel Shot Conversion.

Bulge at mouth of hull – too much crimp start.

Hull buckled – wad not seated deeply enough and/or too much spring pressure at station 6. The shot column is too high and is not compressible so the side wall of the hull buckles.

Loaded round does not feed in a semi-automatic or pump shotgun. The use of the optional Taper Crimp Die is necessary.

### **TAPER CRIMP DIE**

To ensure proper functioning in a semi-automatic or pump shotgun, the optional Taper Crimp Die assembly may be required. The taper Crimp Die provides a more radiused hull mouth for smoother feeding.

This assembly is installed at the empty Station 7 of the Mini Grand. Thread the assembly completely into the press and loosely install the 5/16" Jamb Nut. Insert a loaded round into Station 7 and lower the Handle completely. Lower the assembly over the loaded round with finger pressure. Raise the Handle and adjust the assembly down a further ¼ to ½ turn. Cycle the Handle and check for the desired amount of taper. Raise or lower the assembly as necessary and tighten the Jamb Nut.



### **STEEL SHOT CONVERSION UNIT**

The Steel Shot Conversion unit consists of a larger inner diameter wad seating/shot drop tube. This larger inner diameter allows for the dispensing of large diameter steel shot (#5 and greater). This unit replaces the installed assembly which accommodates #5 shot or smaller.

Installation of Steel Shot Conversion Unit. To prevent a messy mishap, first, remove and empty the Hopper assembly. Using a 15/16" wrench (not provided), remove the Wad Seating/Shot drop assembly from station 4. Install the one piece Steel Shot tube and tighten with the 15/16" wrench. Slide the white O ring onto the drop tube. Re-install the Hopper assembly. Install proper Powder and Shot Bushings.



### **3" and 3 ½" hulls**

To load 3" and 3 ½" hulls, no adjustments are necessary at Stations 1, 2 or 3. Seat wads according to the Component Adjustment section. The Crimp Start (Station 5), Crimp (Station 6) and Taper Crimp (Station 7, if installed) dies need to be raised up to accommodate the longer hulls. Loosen the Jamb Nut and adjust as necessary.

### **MAINTENANCE**

Lubricate the Main Shaft and pivot points of the Handle with a light machine oil or grease.

Periodic cleaning of the Charge Bar channel is necessary to remove powder and lead residue. It is a good practice to clean this area prior to each loading session or when changing bushings.

Use a silicone cloth or a light preservative oil on all blued parts to help to prevent rust.

**This page intentionally left blank**

**This Page intentionally left blank**





**PRECISIONEERED RELOADING EQUIPMENT**

We think that we make the very best reloading equipment in the world. If you agree, please tell your friends. If you disagree, tell us we want to do something about it!

Customer Service

1-800-533-5000 (US or Canada) or 530-533-5191

Hours: Monday - Thursday, 6:30am - 3:00pm Pacific Time  
(hours may vary)

e-mail: [rcbs.tech@atk.com](mailto:rcbs.tech@atk.com) or visit our website at [www.rcbs.com](http://www.rcbs.com)

RCBS 605 Oro Dam Blvd. Oroville, CA 95965

7201360